

FLEXISPOT

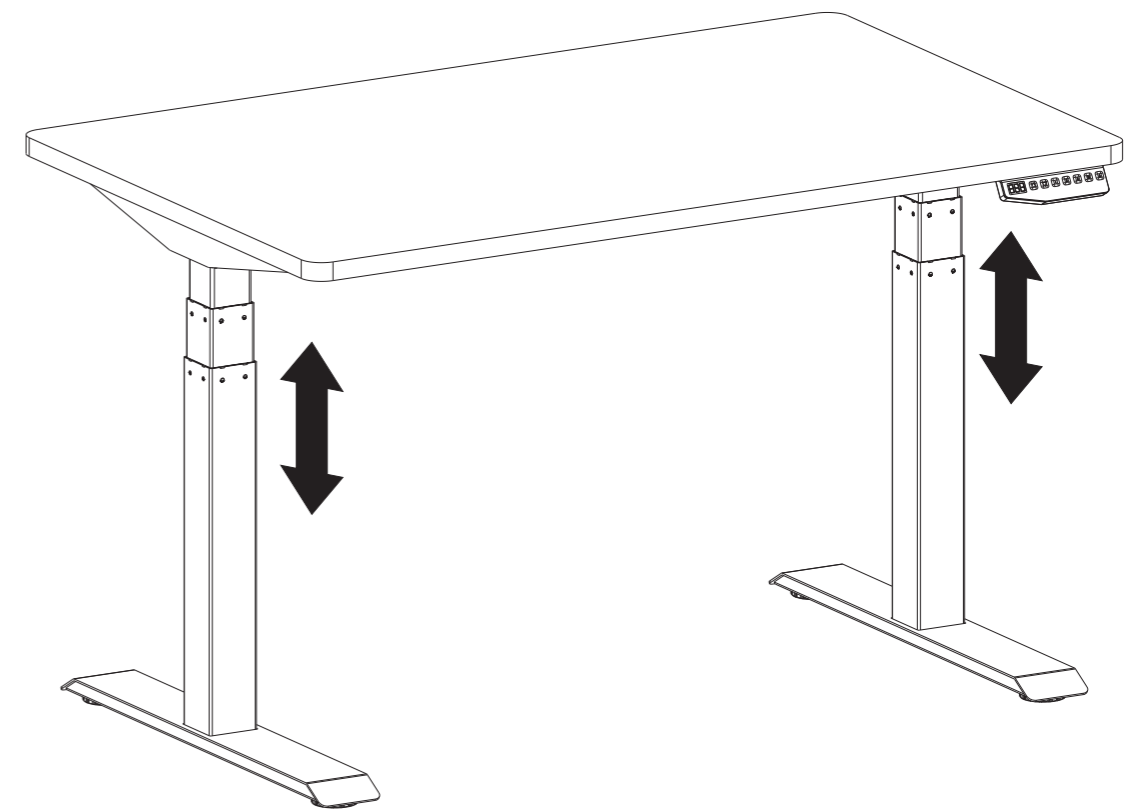

Item No.
E6B-R5530B-CB
E6S-R5530N-CB
Installation Guide

Specifications

Max. Weight Capacity	220 lbs (100 kg)
Max. Speed	1.5 "/s
Input Voltage	100 - 240 V
Height Adjustment	24.8" - 49.6" (630 - 1260 mm)
Desktop Size	55" in width and 30" in depth
Duty Cycle	10% (Working 2 minutes then stop 18 minutes)
Working Temperature	32° - 104° F
Certification Standards	CE FCC CUL

Accessory Package

Figures shown are for reference only. Please contact customer service if there are any accessory or tools missing.

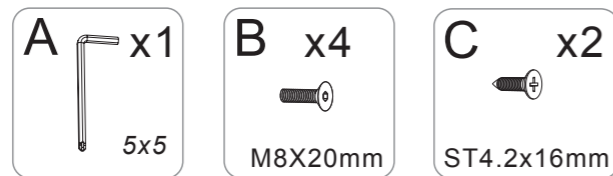

Parts Included

NO.	Parts		Qty		
①			1		
NO.	Parts	Qty	NO.	Parts	Qty
②	 Desk leg	2	③	 Cable Management Plate	2
NO.	Parts	Qty	NO.	Parts	Qty
④	 Power cord	1	⑤	 Handset	1

Diagram of Components



Step 1

Install desk leg (2)

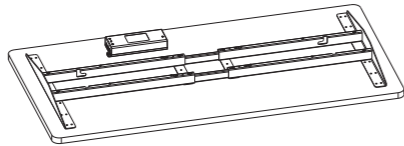
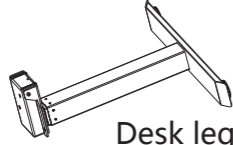
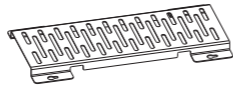
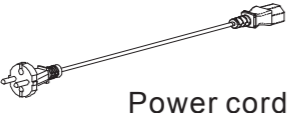
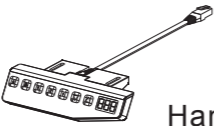
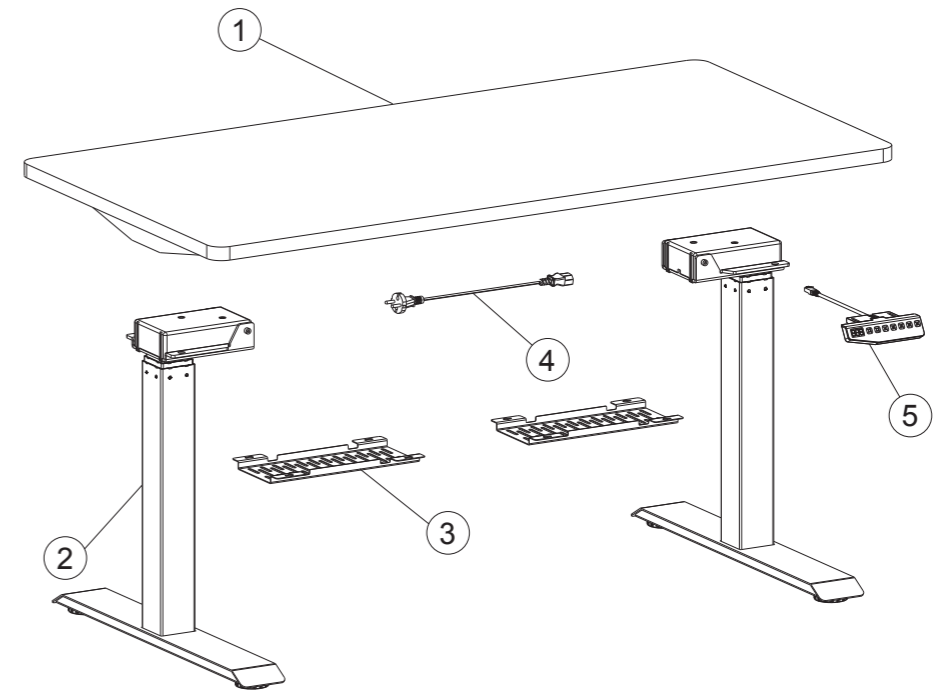
Attaching the desk legs (2) with desktop (1), using 4 M8x20mm (B), tighten with 5x5 hex key (A).

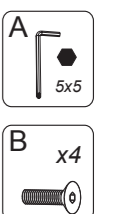
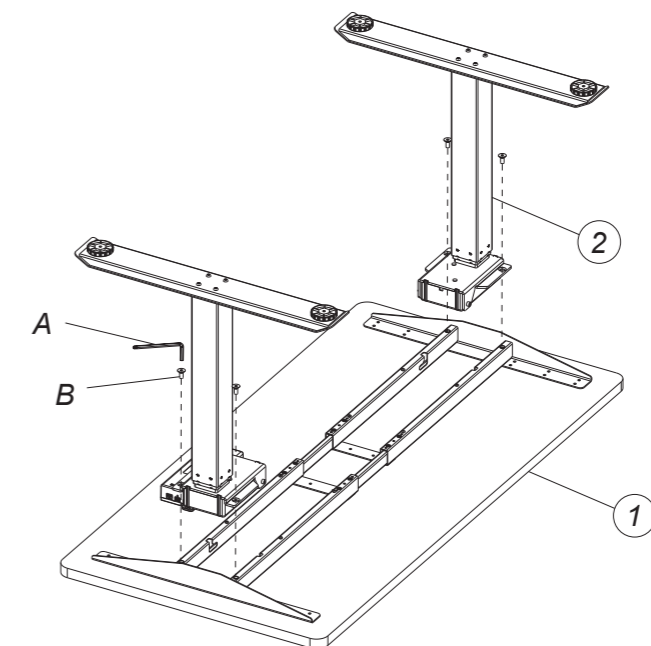

Step 2

Connect the handset cable, power cord and motor cable to the control box as shown on the picture.

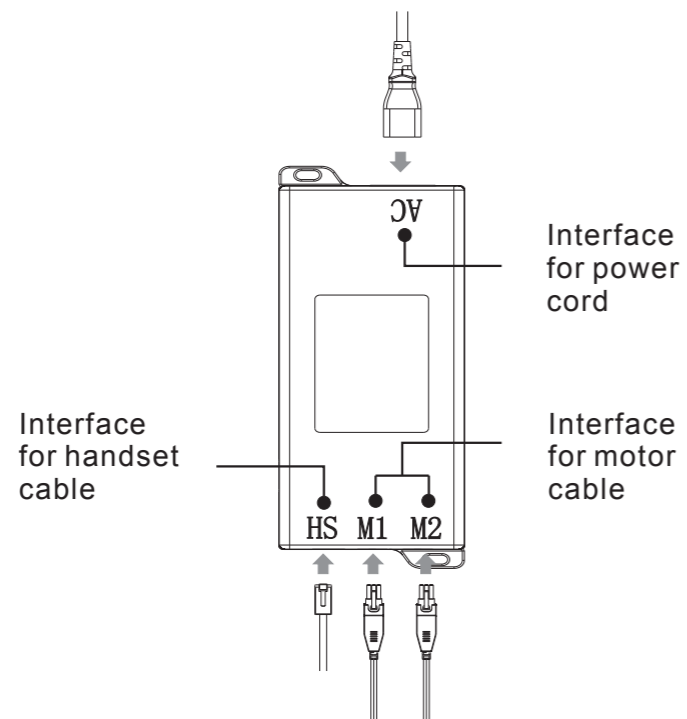
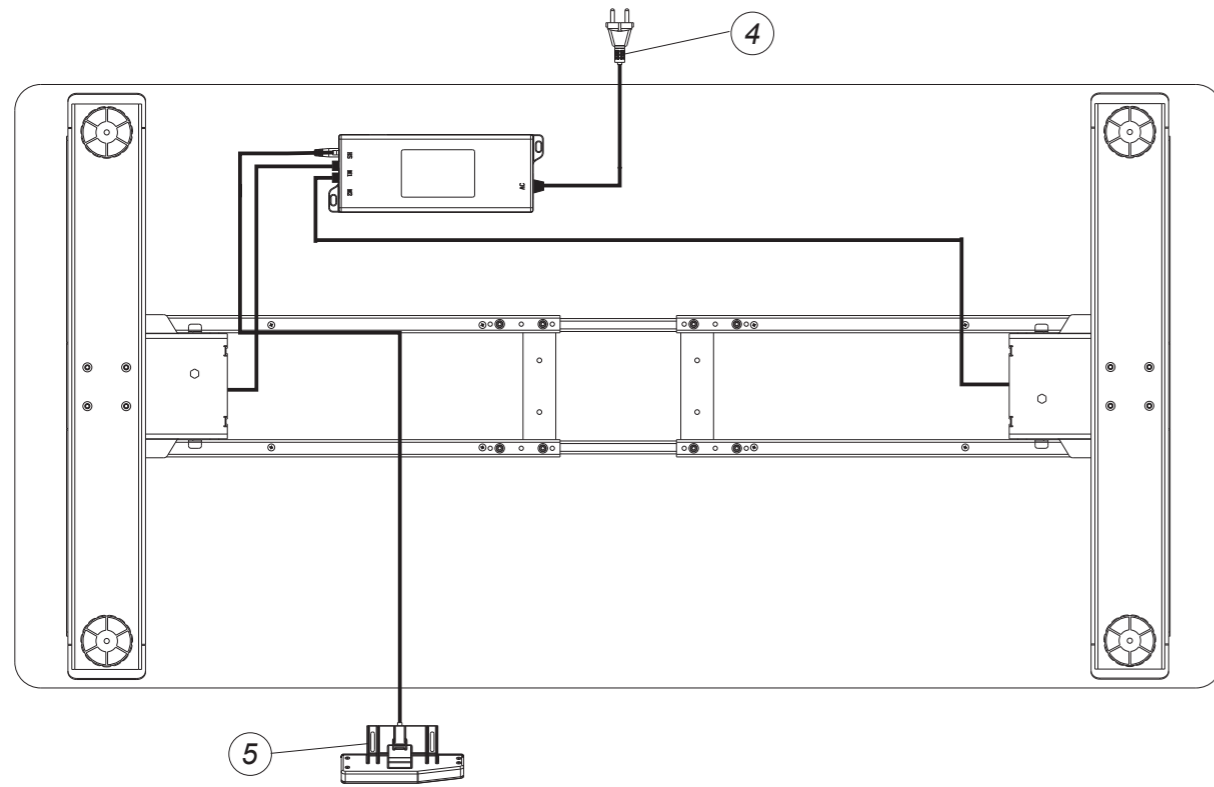

Step 3

Install Cable Management Plate

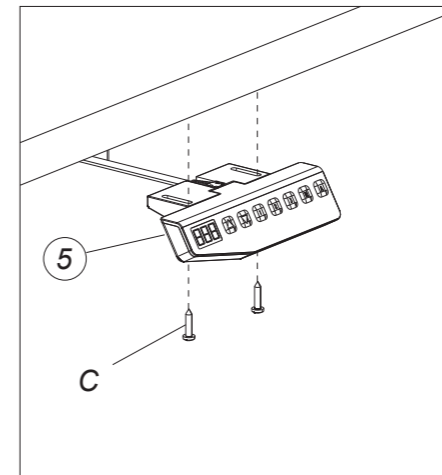
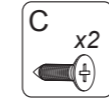
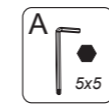

Attaching the handset to the desktop, using 2 ST4.2 x 16mm screws (B).

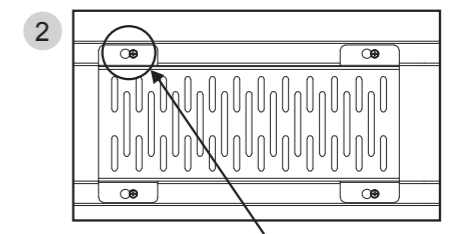
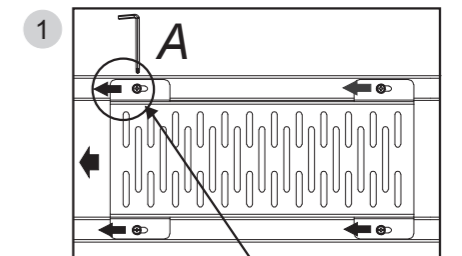
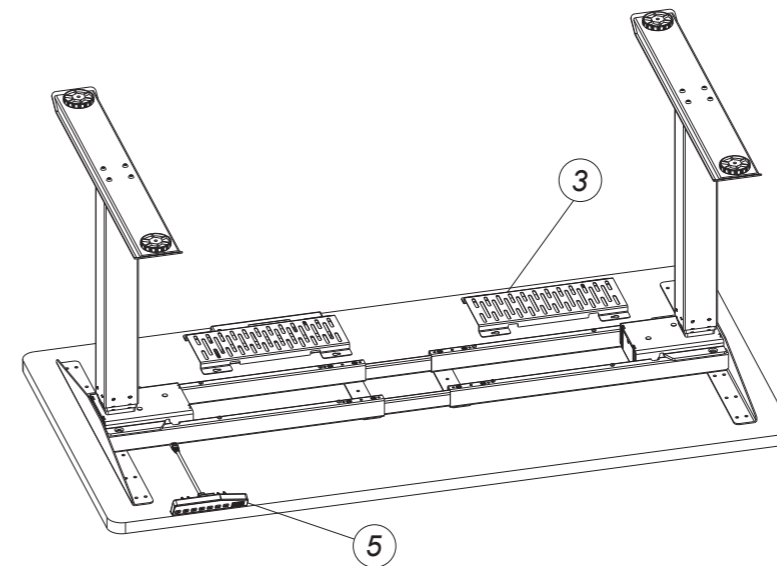

Handset Instruction

Handset

LED Display

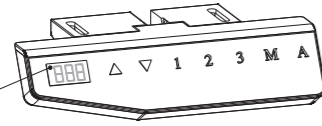

●	"▲"	UP Button, used to lift the desk surface
●	"▼"	DOWN Button, used to lower the desk surface
●	"1"	Position 1, User saves the 1st Height Position
●	"2"	Position 2, User saves the 2nd Height Position
●	"3"	Position 3, User saves the 3rd Height Position
●	"M"	SAVE button, used to save the height position
●	"A"	REMINDER button, used to activate the "Long-Time Sitting Reminder" function

Operation Guide

- Press the UP button or DOWN button to lift or lower the height of desk surface. The LED display shows the real time value. The range of the height value: 27.9" - 48.4".
- Saving A Height Position
 - Press the UP button or DOWN button to lift or lower the height of desk surface. For instance, you adjust the height to 29.5".
 - Press "M" SAVE button and the LED display shows "5-", then press "1" to save the 1st height position to 29.5". The LED display shows "5-1".
 - Repeat step a and step b to save the 2nd height position to 39.5" The LED display shows "5-2". Save the 3rd height position to 47" The LED display shows "5-3".
 - Press "1", "2", "3", to automatically reach the height saved before.
- Long-Time Sitting Reminder
 - Press REMINDER button "A" to activate the function. The LED display shows "00".
 - Two seconds later, press the "▲" or "▼" button to adjust the reminder time only when the display screen flashes. Then press any button to save the time setup, or wait 5 seconds and system will save the time setup automatically. After time setting is finished, the system will automatically enter the countdown, during the countdown, any operation will lead to a repeat starting of the timer. When the countdown finishes, the buzzer will be active with a 10-second "DiDi...DiDi...DiDi..." tone.
 - Within the 10-second reminder buzz, press any button to reactivate the time countdown that is set up in (b) step. If no operation during the 10-second reminder buzz, there will be another reminder buzz after 5 minutes. No operation during the second buzz will turn off the Long-Time Sitting Reminder.
 - Press and hold the "A" button for three seconds to turn off the Long-Time Sitting Reminder. The LED display shows "0FF".
- Troubleshooting
 - Reset function: When LED display shows "RSF", press and hold the "▼" button until the desk reaches its lowest height and rebound to stop and display shows the lowest height, reset process finished.
 - When exception code occurred E01 or E02, please retry 18 mins later.
 - If the "▼" button doesn't work, please check the cable connection and then cut off the power for at least 10 seconds. Reconnect to the power and press "▼" button and LED display shows "RSF", then start the reset process by pressing "▼" button.

After you try all those ways without resolving it, please contact us and we will provide you a new set of cables.

Troubleshooting

This list is used for checking and solving common faults and errors. Please contact the manufacturer if problem you encounter is not on the list below.

Faults	Solution
No action when you press "up" or "down" button	1. Check all cables connected well.
	2. Contact the distributor or the manufacturer.
Speed of lifting is slow	1. Check if the loading weighs more than 154 lbs.
	2. Contact the distributor or the manufacturer.
Motor does not work properly	1. Contact the distributor or the manufacturer.
Can lift but cannot lower down	1. Start the reset process.
	2. Contact the distributor or the manufacturer.
Worksurface downward sliding	1. Check if the loading weighs more than 154 lbs.
	2. Contact the distributor or the manufacturer.
Automatically reset a lot	1. Check if the loading weighs more than 154 lbs.
	2. Contact the distributor or the manufacturer.
Overworked beyond duty cycle: Max 2 min on/18 min off	1. Keep the power on and stop working for 18 minutes.
	2. Contact the distributor or the manufacturer.
The distance lifted or lowered is not accurate	1. Press and hold the "M" and "3" button for three seconds until you hear BEEP twice to restore the factory settings.
	2. Contact the distributor or the manufacturer.

Attention

- Power supply: AC100 - 240 V, frequency 50/60HZ;
- Working environment: 32° - 104° F;
- Before cleaning, you have to unplug the power supply cable. Clean with a slightly damp cloth to wipe away the surface dust. Keep all electrical components away from liquids. Do not damage the connection line and keep the plug in a safe position.
- Inside the control box, there are electronic components, metal parts, plastic parts, wires and so on. They should be disposed in accordance with the local laws and regulations. They cannot be disposed as household waste.
- Before using the product, please make sure the product has been installed correctly.
- Before starting use of the product, please read the instructions to fully understand all the product's functions and settings.
- Keep children away from electric height-adjustable desks, control units and handsets. Manufacturer is not responsible of any damages that result from children's unpredictable behaviour.
- Slight noise caused by the multi wedge belt or brake system will not impact the use of this product.
- Do not use corrosive or abrasive materials to clean this product and please dispose of cleaning solutions in an environmentally friendly manner.
- Understand the risks associated with using this product. Children or those with cognitive impairment should not use this product without supervision.
- If the power supply cord is damaged or broken, it must be replaced by the manufacturer or a relevant specialist to avoid any injuries.
- Please operate in a clean and safe environment. For example, do not left around your tools. And always be careful to deal with packaging materials, in order to avoid any kinds of possible danger. Potential choking risk exists when children play with plastic bags!
- If necessary, retain the original package for future transportation.

Recycling and Disposal



This product cannot be disposed of as household waste. To prevent damage to the environment, this product should be recycled. Please use the relevant recycling systems available to you or contract the distributor or manufacturer for recycling assistance.

FlexiSpot Limited Warranty

This limited warranty offered by FlexiSpot covers defects in material or workmanship in new FlexiSpot products. This warranty extends to the original purchaser only and is non-transferable. Only consumers purchasing FlexiSpot products from authorized FlexiSpot retailers or resellers may benefit from our limited warranty.

What is Covered?

The FlexiSpot limited warranty covers our products against defects in material or workmanship as follows:

- FlexiSpot Height Adjustable Desk Frames

All height-adjustable desks purchased on or after October 5, 2016 include a 5-year warranty for the frame, and a 3-year warranty for the motor, controller and switch, electronics and other mechanisms.

- FlexiSpot Sit-Stand Desktop Workstations

All standing desks purchased on or after October 5, 2016 include a 5-year warranty for the frame, medium-fiber desktop and mechanisms.

- FlexiSpot Desk Bikes

All desk bikes purchased on or after October 5, 2016 include a 3-year warranty for the frame, and a 1-year warranty for the electronics and other mechanisms.

- FlexiSpot Mini Steppers

All desk bikes purchased on or after October 5, 2016 include a 1-year warranty for the frame, and other mechanisms.

- Accessories

All monitor mounts purchased on or after October 5, 2016 include a 5-year warranty for the arms, 3-year warranty for gas spring system and mechanisms.

What are your Remedies?

FlexiSpot will replace at no charge to the consumer the defective parts only or, at FlexiSpot's option, replace any product or part of the product that is defective because of improper workmanship and/or material, under normal installation, use, service and maintenance. If FlexiSpot is unable to provide a replacement and repair is not practical or cannot be completed in a timely fashion, FlexiSpot may elect to refund the purchase price in exchange for the return of the product. In the rare event that your FlexiSpot product is defective, we will provide you with a replacement item shipped at no cost to you within the continental United States. The shipping method for replacement products is FedEx Ground, but expedited shipping is available if you choose to pay the additional expense. In addition, you will need to pay the shipping costs if any products need to be shipped to you at an address outside the continental United States.

REPAIR OR REPLACEMENT (OR, IN LIMITED CIRCUMSTANCES, REFUND OF THE PURCHASE PRICE) AS PROVIDED UNDER THIS WARRANTY IS THE EXCLUSIVE REMEDY OF THE PURCHASER. FLEXISPOT NEITHER ASSUMES NOR AUTHORIZES ANY PERSON TO CREATE FOR IT ANY OTHER OBLIGATION OR LIABILITY IN CONNECTION WITH THIS PRODUCT.

FlexiSpot Limited Warranty

What is Not Covered?

Our limited warranty does not cover any problem that is caused by:

1. Conditions, malfunctions or damage not resulting from defects in material or workmanship.
2. Conditions, malfunctions or damage resulting from normal wear and tear, improper installation, improper maintenance, misuse, abuse, negligence, accident or alteration.
3. Accessories, connected materials and products, or related products not manufactured by FlexiSpot.
4. Conditions, malfunctions or damage resulting from failure to follow the instructions and guidelines relating to the product's intended use.

Our limited warranty is void if a product is returned with removed, damaged or tampered labels or any alterations (including removal of any component or external cover).

How to File a Claim?

In order to receive the benefit of our limited warranty, you need to process your claim in compliance with the terms of this limited warranty and follow proper return procedure. To request warranty service, please contact customer service via email at contact@FlexiSpot.com or toll free at 855-421-2808. You will need to provide the sales receipt or other evidence of the date and place of purchase for your FlexiSpot product.

Implied Warranties and Limitation of Damages

EXCEPT TO THE EXTENT PROHIBITED BY APPLICABLE LAW, ALL IMPLIED WARRANTIES (INCLUDING WARRANTIES OF MERCHANTABILITY AND FITNESS FOR A PARTICULAR PURPOSE) SHALL BE LIMITED IN DURATION TO THE DURATION OF THIS WARRANTY, AND FLEXISPOT SHALL NOT BE LIABLE FOR ANY INCIDENTAL, INDIRECT, SPECIAL, OR CONSEQUENTIAL DAMAGES, INCLUDING BUT NOT LIMITED TO LOSS OF PROFITS OR REVENUE, RESULTING FROM ANY BREACH OF EXPRESS OR IMPLIED WARRANTY OR CONDITION, OR UNDER ANY OTHER LEGAL THEORY, EVEN IF FLEXISPOT HAS BEEN ADVISED OF THE POSSIBILITY OF SUCH DAMAGES. Some jurisdictions do not allow limitations on the duration of an implied warranty or the exclusion or limitation of special, indirect, incidental or consequential damages, so the above limitations or exclusions may not apply to you.

Governing Law

This Warranty shall be governed by the laws of the State of California, USA, without giving effect to any conflict of laws principles that may provide the application of the law of another jurisdiction.

How State Law Applies

This Warranty gives you specific legal rights, and you may also have other rights which vary from state to state.